

# SpeedChanger<sup>®</sup> INSTALLATION SYSTEM REFERENCE

REVISION 2  
OCTOBER 23, 2002

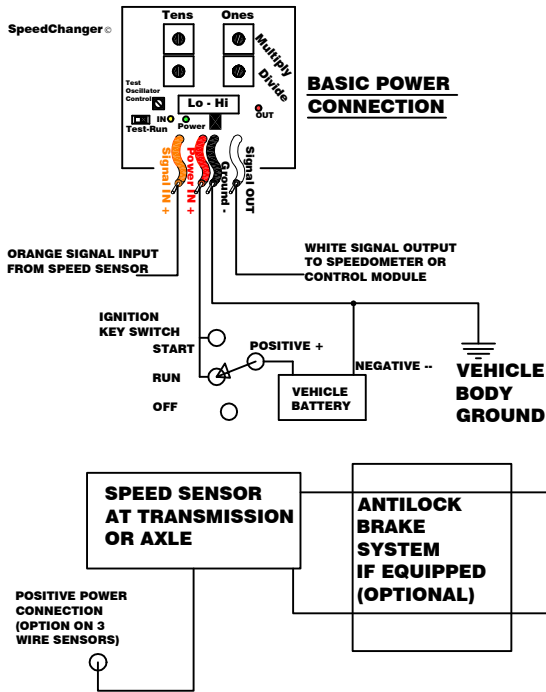

**THIS CONFIGURATION USED TO EFFECT COMPUTER RELATED FUNCTIONS SUCH AS SHIFT POINTS AND MAX VEHICLE SPEED. DO NOT CONNECT HERE IF ANTILOCK BRAKE SYSTEM OR AIRBAG IS CONTROLLED BY THE COMPUTER!!**

## **BEST CONFIGURATION**

**THIS CONFIGURATION USED TO EFFECT ONLY THE SPEEDOMETER AND IS SUGGESTED ... ESPECIALLY IN SYSTEMS WITH MANUAL TRANSMISSIONS.**

